

C03U

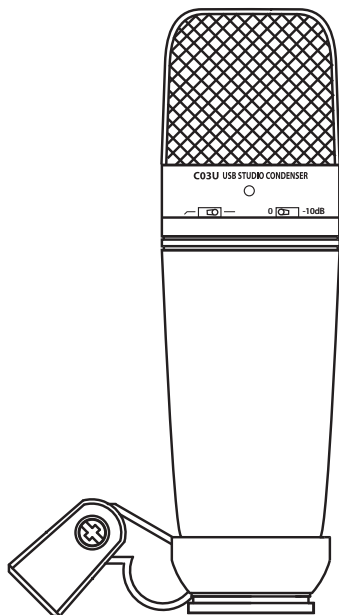

MULTI-PATTERN USB CONDENSER MICROPHONE

Owner's Manual

SAMSON

Introduction

Congratulations on your purchase of the Samson C03U studio condenser. The C03U features a large, 19mm ultra thin diaphragm capsule with an onboard high quality Analog-to-Digital converter and USB output. The C03U is perfect for recording your music, or any acoustic audio source on your favorite DAW (Digital Audio Workstation). Just plug in the supplied USB cable, launch your DAW and start recording. For expanded control, install the Samson C03U driver software and you'll have additional features like programmable GAIN, Low Cut Filter, Input Metering and Phase switch. The C03U faithfully reproduces a variety of sound sources including vocals, acoustic instruments and overhead cymbals, to name a few. The extended frequency and fast transient response insures an accurate reproduction with linear characteristics from bottom to top.

In these pages, you'll find a detailed description of the features of the C03U Studio Condenser Microphone, as well as step-by-step instructions for its setup and use, and full specifications. You'll also find a warranty card enclosed—please don't forget to fill it out and mail it in so that you can receive online technical support and so we can send you updated information about these and other Samson products in the future.

With proper care and adequate air circulation, your C03U will operate trouble free for many years. We recommend you record your serial number in the space provided below for future reference.

Serial number: _____

Date of purchase: _____

Should your unit ever require servicing, a Return Authorization number (RA) must be obtained before shipping your unit to Samson. Without this number, the unit will not be accepted. Please call Samson at 1-800-3SAMSON (1-800-372-6766) for a Return Authorization number prior to shipping your unit. Please retain the original packing materials and if possible, return the unit in the original carton and packing materials.

C03U Features

- Large Diaphragm, 19mm, Multi-pattern, Studio Condenser with USB Digital Output.
- Compatible with any computer based Digital Audio Workstation.
- Hyper Cardioid, Omni and BiDirectional pick-up patterns.
- The extremely detailed sound reproduction makes it ideal for recording vocals, acoustic instruments and just about any other sound source.
- High Quality AD convertor with 16 Bit, 48K sampling rate.
- Software drivers for MAC and PC provide additional features like Programmable Gain, LED Input Metering, Low Cut Filter, and Phase.
- Dual 19mm Capsules with 3-micron Diaphragm.
- Solid Die Cast construction.
- Swivel Stand Mount and 10 foot USB cable included.

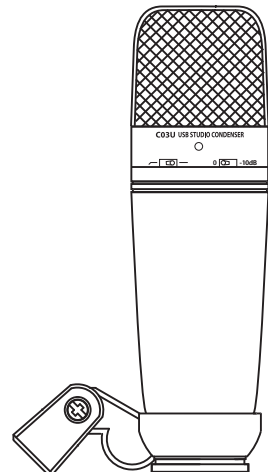

Installing the C03U

Installing the C03U is a simple procedure that takes just a few minutes. Since the C03U is USB compliant, you can use either a MAC or PC, connect the included USB cable and plug and play. You will be able to control your C03U using the standard audio interface controls in the MAC or Windows operating system. You will find detailed instructions on setting up with MAC OS and Windows in the following sections of this manual.

For expanded control, you can install the Samson Softpre applet which will give you programmable Gain and a digital Input Meter so you can adjust the internal, digitally controlled microphone pre-amplifier to the correct level. You can also use the Low Cut Filter to remove unwanted low frequency rumble. There's even a Phase switch so you can invert the signal polarity when using multiple microphones.

Since it is possible to adjust the level of the signal from the operating system preferences, and in your recording software, it's a good idea to be familiar with these controls in the MAC or Windows operating system. Therefore, we recommend that you follow the section Getting Started with Windows XP (and 98) or Getting Started with MAX OS X before installing the C03U software driver.

IMPORTANT NOTE: *The Softpre applet is not compatible with every recording software program, so we recommend that you install the microphone on your computer **without** the Softpre first. Then, please check our website for a list of programs that work with the Softpre applet.*

Getting Started with MAC OS X

The following example is for setting up the C03U in MAC OS X .

1. Plug in microphone. The LED will light to indicate it is receiving USB power. The MAC will recognize the USB audio device and automatically install a universal driver.

2.To select the C03U as the computers audio input, open the System Preferences from the dock or the main Apple Menu (figure 1).

3. Next open the Sound preference (figure 2).

4. Now, click in the Input tab and select C03U (figure 3).

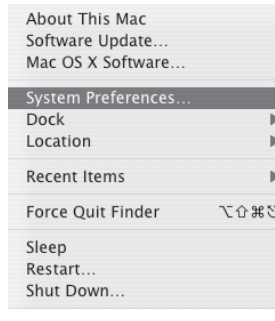

Figure 1



Figure 2



Figure 3

Getting Started with Windows XP

The following example is for setting up the C03U in Windows XP with Service Pack 2. Other versions may vary slightly.

1. Plug in microphone. The LED will light to indicate it is receiving USB power. Windows will recognize the USB audio device and automatically install the universal drivers (figure 1). (These balloons will not appear next time you plug it in, as the microphone drivers are already installed.)

The C03U is now recognized as a Windows audio device under the name Samson C03U. Each additional C03U will have a number added, such as Samson C03U (2), and so on. To set it as the default device and change computer-controlled gain, access control panel.

2. Access Sounds and Audio Devices through Control Panel (figure 2).

3. Select Samson C03U as Sound recording Default device under the Audio tab. The default device is used in simple programs like those for teleconferencing or Sound Recorder. In most pro audio programs you can select which device (or multiple devices) to use within the program itself. To set computer-controlled gain, click the Volume button (figure 3).

4. The Wave In window sets the computer-controlled gain or mutes the microphone. The gain is from -62 dB to $+48$ dB (figure 4).



Figure 1



Figure 2

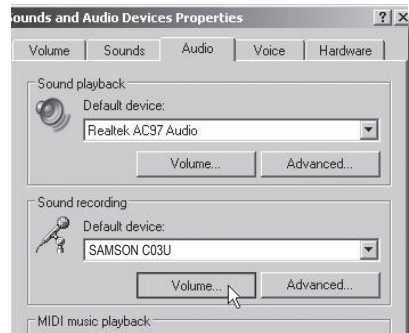

Figure 3

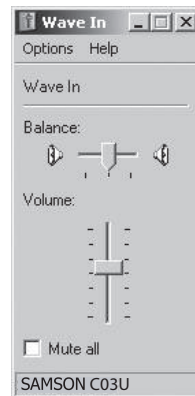

Figure 4

Using the Softpre Software Applet

Installing the Softpre Software

The C03U can work with most audio software by simply connecting the microphone to your computer using the supplied USB cable. However, to take advantage of the advance features you should install the Samson C03U software. Getting the software is easy. Just type samsontech.com into your favorite internet browser, look for the C03U driver link and follow the on screen instructions to download the driver. After you download the driver software, run the installation program and start to use the C03U software.

Once you have the C03U software installed you can operate your C03U by following the simple instructions outlined in the following sections of this manual.

Setting a Good Level

One of the most important fundamentals of good audio engineering is setting proper levels. Even on a small typical mixer, or basic multi-track recorder, there are several controls that affect the level of a signal as it makes it's way from your sound source to your speakers and then, ultimately, the level of your headphone or monitor system. These include pre-amp gain, EQ, aux sends and returns, channel fader level, bus or group levels, and finally, the master fader. That's not to mention the level of the 5:15 train on its way to Pennsylvania Station who's thunderous crossing horn can be picked up from 5 miles away while miking a nylon string guitar, despite the use of double moving blankets over the windows of your project studio. But that's another story with another set of disciplines. Start off by being aware that anytime you change any control in the audio path, you are probably affecting gain somewhere. Then, be sure to carefully monitor the levels on your input and output meters to avoid a clipped signal with too many peaks. Also, remember your ear is the most sophisticated and calibrated piece of test gear you have. So, setting a good level should be approached from a technical point of view, and then confirmed, by a creative point of view.

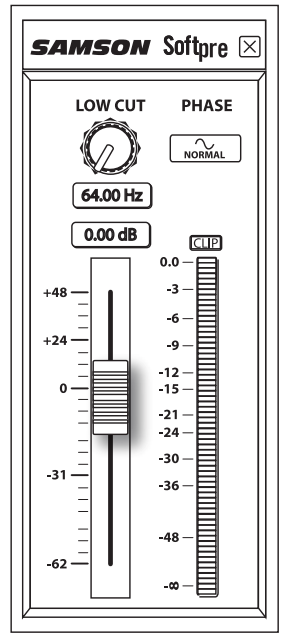

INPUT GAIN – Fader

The C03U has an onboard, digitally controlled analog INPUT GAIN stage which is controlled by the C03U software fader. The fader control provides a range of gain from -62 to +48 dB. The C03U can accept levels from most any sound source by using the INPUT GAIN fader. You can use the INPUT GAIN control to adjust the level of your input signal. It is a good idea to start with the level low and raise it up as you need. Be sure to monitor the input digital VU METER and try to set the INPUT GAIN control so that the meter reads just below the CLIP indicator. If you see the CLIP indicator light you are “Over-Loading” and the sound may become distorted. If this happens, simply back down on the INPUT GAIN Fader. The CLIP indicator will stay red until you clear it by clicking on the CLIP icon.

Using the Softpre Software Applet

DIGITAL VU METER - Input Level

To monitor the signal being sent from the C03U, there is an digital VU METER with a scale from infinity to Digital Mximum or CLIP. The level displayed on the meter will be affected by the Input Gain Fader so be sure that you have that set to the correct position for your sound source. The digital VU METER features "VU" ballistics, which means it reacts to the signal based on an average level. Use the VU METER when you are setting your input level using the GAIN control. Try to set the level so that the meter reads about just below CLIP but so that it never goes to CLIP. If you see the CLIP indicator light you are "Over-Loading" and the sound may become distorted. If this happens, simply back down on the INPUT GAIN Fader. The CLIP indicator will stay red until you clear it by clicking on the CLIP icon.

Using the Low Cut Filter

Like any good mic pre, the C03U software features a Low Cut, (or High Pass), filter for attenuating the bottom-end frequencies. The Low Cut filter allows you to remove the lower frequencies that you sometimes just don't want to pick up. For example, when you are miking a high-hat you only want to capture the frequencies that the hi-hat is producing. Therefore, by using the Low Cut filter, you can reduce the amount of pick-up from the low toms and bass drum that may leak into the hi-hat mic. You can use the same technique on other instruments like acoustic guitar, violin, piano and even on vocals. In live sound applications, the Low Cut filter is especially useful for removing stage rumble. The Softpre software provides a variable Low Cut filter that allows you to adjust the exact frequency at which the low frequencies begin to roll-off, or attenuate.

PHASE – Switch

For a variety of miking and mixing techniques, it may be necessary to invert the signal phase from the source you have plugged into your C03U and Softpre software. When the PHASE switch is pressed in, the yellow LED will light showing that the input signal is now out-of-phase.

Powering the C03U

The C03U is a condenser microphone, and like all condenser microphones, it has internal electronics that require an active power supply. Traditional studio condensers are almost always powered by a Phantom Power supply which is usually derived from the mixing console. The C03U receives its power from the USB bus. Simply connect the microphone to the computers USB port and the microphone is ready to operate. The C03U features a power on LED, which will illuminate when USB power is present.

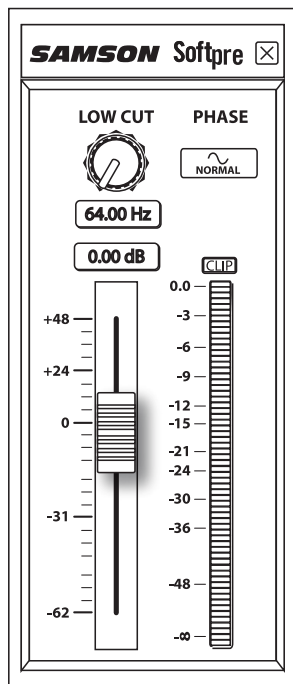

Using the PAD Switch

The C03U includes a PAD switch, which you can use to lower the input sensitivity of the microphone. When the PAD switch is set at the 0dB position the PAD is bypassed and there is no effect on the signal. When the PAD switch is set to the -10dB position, the microphone's input sensitivity will be lowered by 10dB. You can use the PAD when you are miking loud sound sources with a high SPL (Sound Pressure Level).

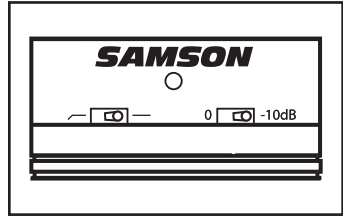

2 Using the Hi-Pass Filter

The C03U offers a user selectable hi-pass, or low-cut filter, which you can use to eliminate any unwanted low frequency reproduction. When the Hi-pass Filter is set to the "flat" (indicated by the straight line) position, there is no effect on the signal. When the Hi-pass switch is set to the "roll-off" position (indicated with the angled line), a 12dB per octave low-cut at 100Hz is applied to the signal. This can be extremely useful for removing low frequency stage rumble, wind noise during outdoor use, and filtering out lows from drums when used as overhead cymbal microphone on a drum kit.

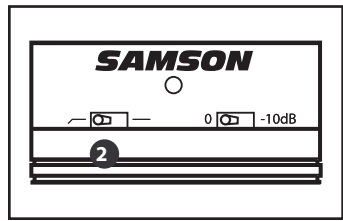

Polar Patterns

The most important characteristic of any microphone is its directionality or "pickup pattern". The C03U's versatile dual capsule design is capable of producing three useful pick up patterns; Cardioid, Omni, and Figure 8. It is easy for you to select the pickup pattern using the C03U's pattern selection switch located on the rear of the microphone. When choosing a pattern, you should be aware of the phenomenon known as the "proximity effect".

Simply put, proximity effect is the change in frequency response as the microphone position is changed relative to the sound source. Any microphone exhibits its best frequency response when pointed directly at the sound source (on-axis). Depending on the pickup pattern, the low frequency response will increase, sometimes greatly, when positioned less than 12 inches away from the sound source (off-axis). Understanding and knowing how to use the proximity effect can be a tremendous help in getting just sound you looking for. The following sections details the three available pickup patterns.

Operating the C03U

3 Super Cardioid

While Omni and Bi-directional microphones are very useful for a variety of specialty applications, the majority of miking situations in recording and live sound require uni-directional or Cardioid microphones. The C03U condenser's pickup pattern is Super-cardioid, which offers even more side-to-side rejection. The uni-directional nature allows for better separation of instruments in the studio and more control over feedback in live sound reinforcement. To select the Super Cardioid pickup pattern, set the pattern selection switch to the center, Super Cardioid position indicated by the "heart shaped" icon. When positioned correctly, the Super-cardioid pickup pattern allows you to pick up more of the sound you want and less of the sound you don't want.

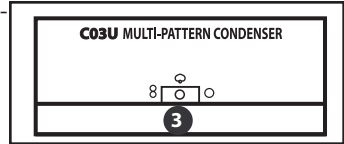

4 Omni

Omni, or omni-directional, microphones pick up sound from all directions. To select the Omni pickup pattern, set the C03U's pattern selection switch to the right, "O" position. You can use the omni pickup pattern if you want to capture the ambient sound and natural reverb in a room where an instrument or voice is being recorded. The Omni mode is also great for recording ensemble performances from groups of vocals, brass, woodwind and other instruments with the artists facing each other in a circle around the microphone. As an added benefit, the omni pattern is the least susceptible to the proximity effect. This can be extremely useful when recording artists who have a tendency to move their instrument, including their voice, around the microphone while performing. In these situations, using a cardioid pattern can result in the frequency response changing tremendously with just a few inches of movement resulting in a recorded track with the lows moving up and down in volume. Using the omni pick up pattern can help control these tricky miking situations allowing you to capture the best performance without inhibiting the talent by forcing them to try to stay in a fixed position.

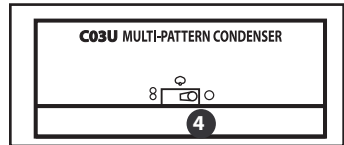

5 Figure 8

Figure 8, or bi-directional, mics pick up the sound directly in front and back of the microphone while rejecting the sound on the left and right sides. To select the Figure-8 pickup pattern set the C03U's pattern selection switch to the left, "8" position. In this mode it's almost like having two identical microphones facing back-to-back to each other. This can be an ideal setting for capturing two artists singing a duet or laying down a background vocal track. Having the two artists face each other while performing can help capture the emotions that may otherwise be missed if two microphones are used. You can also create some interesting slap back echo effects by positioning the C03U in Figure-8 pattern between a recorded instrument and a particular wall in the studio. The rear capsule will pick up the reflection of the sound off the wall, and by changing the distance of the microphone from the wall you can actually change the delay time of the echo.

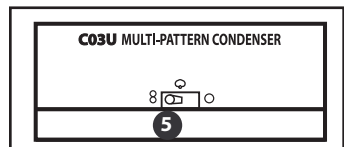

Microphone Placement

In order to maximize the sound quality, you must pay careful attention to the placement of your C03U and how it is positioned for the instrument or vocalist that you are miking. All microphones, especially uni-directional or cardioid microphones, exhibit a phenomenon known as “proximity effect.” Very simply put, proximity effect is a resulting change in the frequency response of a microphone based on the position of the mic capsule relative to the sound source. Specifically, when you point a cardioid mic directly at the sound source (on axis) you will get the best frequency response, however when you start pointing the microphone slightly away (off axis) you will notice the low frequency response dropping off and the microphone will start to sound thinner.

For most vocal applications you’ll want to position the microphone directly in front of the artist. The same may be true for miking instruments, however, you can make some pretty amazing equalization adjustments by slightly changing the angle of the capsule to the sound source. This can be a very useful technique in capturing the optimum sound of drum set, acoustic guitar, piano or other instruments in a live room or sound stage. Experimentation and experience are the best teachers in getting good sounds, so plug in!

Setting Up the Signal Level

You can adjust the C03U’s internal digitally controlled analog Input Gain stage by using the Softpre applet, or you can control the input gain by using the software control in your computer’s operating system and/or digital audio workstation. Either way, the purpose of the mic trim control is to optimize the amount of good signal to any associated noise. A good mic pre, like the C03U software control panel, will also have LEVEL or CLIP indicators. To set a good level on the mic, set the C03U up in front of the desired sound source and slowly raise the input trim control until you see the CLIP or Peak indicator light up. Then, turn the input trim control down until the indicator does not light any more. *For more information on setting the Input Gain with the Softpre applet, see the section “INPUT GAIN - Fader” on page 7 in this manual.*

P-Popping

P-Popping is that annoying pop that you can get when the microphone diaphragm gets a blast of air from a vocalist pronouncing words with the letter “P” included. There are a few ways to deal with the problem including using an external pop filter. Some famous engineers have relied on an old nylon stocking over a bent clothes hanger, which actually works very well. You can also try placing the microphone slightly off axis (on a slight angle) from the vocalist. This can often solve the problem without using an external pop filter. However, for a more reliable solution, try an external pop filter like the Samson PS-01.

Stand Mounting the C03U

The C03U can be mounted to a standard microphone stand using the included swivel mount adapter. If you are using a U.S. 5/8” mic stand, you will need to remove, by unscrewing, the Euro stand adapter. Simply screw the swivel adapter on to your mic stand or boom arm. Now, loosen the thumbscrew and adjust the microphone to the desired angle. Once set, tighten the thumbscrew to secure the microphone in place.

Using the Optional SP01 Shock-Mount

Using the Optional SP01 “Spider” Shock-Mount

For additional isolation the C03U can be fitted on the optional SP01 “Spider” shock mount. Follow the steps below to install the SP01.

- First, screw the SP01 shock mount onto your mic stand or boom arm. If you’re using a US 5/8” mic stand or boom, remove the Euro adapter.
- Remove the C03U swivel mount by rotating the threaded collar counter-clockwise as shown in figure 1.
- Install the C03U into the SP01 by fitting the microphone into the center of the web, positioning the C03U onto the bottom mounting plate.
- Secure the SP01 by reinstalling the threaded collar, rotating clockwise until tight. (Figure 2)
- Now, loosen the thumb screw to adjust the angle of the microphone and position the C03U to the desired location. Once set, tighten the thumbscrew to secure the microphone in place.

Note: Be careful not to cross thread or over tighten the threaded collar or thumb screw.

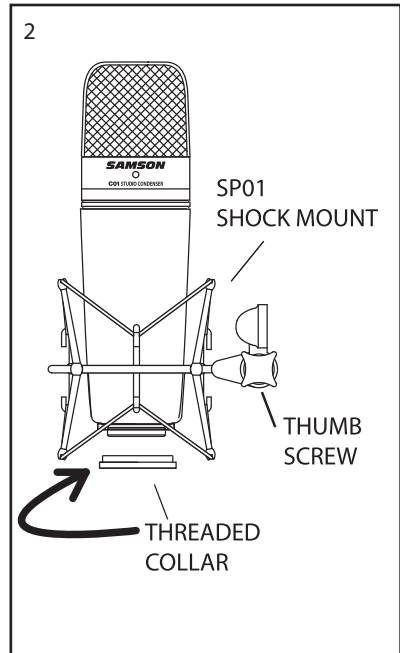
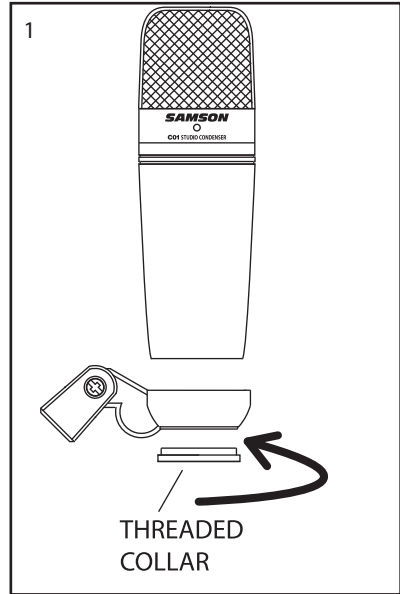

C03U Specifications

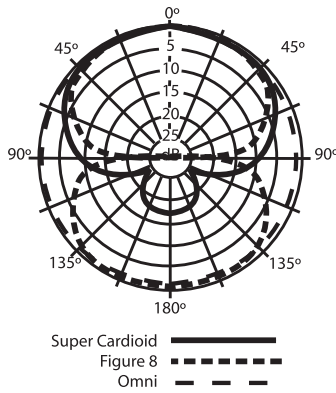
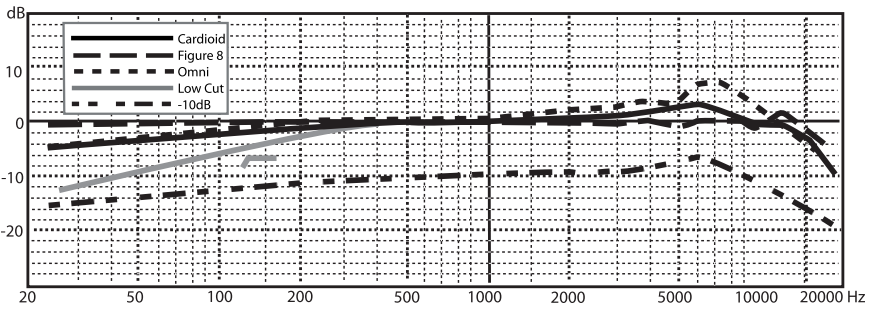

Specifications / Caractéristiques techniques / Technische Daten

C03U Specifications

Frequency Response	20~18000 HZ
Polar pattern	Super Cardioid, Omni, Bi-directional
Element type	Back condenser type
Diaphragm thickness	3 microns
Sensitivity	-33 dB/Pa
SPL	136 dB
Weight	1.06 lbs. (.48 kg)
Dimensions	Height: 7" (180 mm) Width: 2.125" (54 mm) Depth: 2.125" (54 mm)
Shipping Weight	2.5 lbs.(1.15 Kg)

Specifications subject to change without notice.

C03U - Caractéristiques techniques

Réponse en fréquence	20~18000 Hz
Diagrammes polaires	Hyper cardioïde, omni-directionnel, bi-directionnel
Type d'élément	Condensateur arrière
Épaisseur du diaphragme	3 microns
Sensibilité	-33 dB/Pa
Niveau SPL	136 dB
Poids	0,48 kg
Dimensions	Hauteur : 180 mm Largeur : 54 mm Profondeur : 54 mm
Poids à l'expédition	1,15 kg

Ces caractéristiques techniques peuvent être modifiées à tout moment sans préavis.

C03U Technische Daten

Frequenzgang	20~18000 Hz
Richtcharakteristik	Superniere, Omni, bidirektional
Element-Typ	Back-Kondensatormikrofon
Membrandicke	3 Mikron
Empfindlichkeit	-33 dB/Pa
Schalldruckpegel	136 dB
Gewicht	0.48 kg (1.06 lbs.)
Abmessungen	Höhe: 180 mm (7") Breite: 54 mm (2.125") Tiefe: 54 mm (2.125")
Transportgewicht	1.15 kg (2.5 lbs.)

Technische Daten können unangekündigt geändert werden.