

**SAMSON®**

**auro** Powered Loudspeakers

**D412**  
**D415**



**400 Watt 2-Way Powered Loudspeakers**

ENGLISH

FRANÇAIS

DEUTSCHE

ESPAÑOL

ITALIANO

**OWNERS MANUAL**

Thank you for purchasing the Samson Auro professional, powered loudspeaker. The Auro D412 and D415 are compact and powerful speaker cabinets featuring 400 watts of bi-amped onboard power. The Auro D412 and D415, respectively, feature 12" and 15" heavy-duty, long-excursion woofers, as well as 1.34" titanium compression drivers on 1" throat wide dispersion horns. The speaker cabinets provide both XLR and ¼" phone jacks that handle microphone or line level inputs. The XLR Line Output allows you to "daisy-chain" multiple Auro cabinets together to create larger sound reinforcement systems.

For added speaker protection, the Auro D412 and D415 feature dual optical limiters that keep your speaker sounding perfect at any level, and the integrated two-band equalizer allows you to sculpt the mix to your desired sound. Each cabinet's trapezoidal shape allows it to be configured for either front-of-house use, or for operation as a wedge-style monitor. In addition, the compact cabinets can easily be stacked, using the built-in bumpers or can be stand-mounted using the integral 1 3/8" pole-mount receptacles.

Each Auro PA system's durable enclosure is made of high-impact polypropylene with a scuff-resistant textured finish, and include a heavy-grade steel grill, offering excellent protection against wear and tear for truly portable audio. The Auro active monitors are ideal for live music, DJ, lecture, and installed sound applications, or anywhere serious power and superior sound quality are desired.

In these pages, you'll find a detailed itemization of the features of the Auro PA stracsystem, as well as a description of its front and rear panels, step-by-step instructions for its setup and use, and full specifications. You'll also find a warranty card enclosed—please don't forget to fill it out and mail it in so that you can receive online technical support, and so that we can send you updated information about this and other Samson products in the future. Also, be sure to check out our website ([www.samsontech.com](http://www.samsontech.com)) for complete information about our full product line.

With proper care and adequate air circulation, your Auro cabinet will operate trouble free for many years. We recommend you record your serial number in the space provided below for future reference.

Serial number: \_\_\_\_\_

Date of purchase: \_\_\_\_\_

Should your unit ever require servicing, a Return Authorization (RA) number must be obtained before shipping your unit to Samson. Without this number, the unit will not be accepted. Please call Samson at 1-800-3SAMSON (1-800-372-6766) for an RA number prior to shipping your unit. Please retain the original packing materials and, if possible, return the unit in the original carton and packing materials. If you purchased your Samson product outside the United States, please contact your local distributor for warranty and service information.

---

## Auro D412/D415 Features

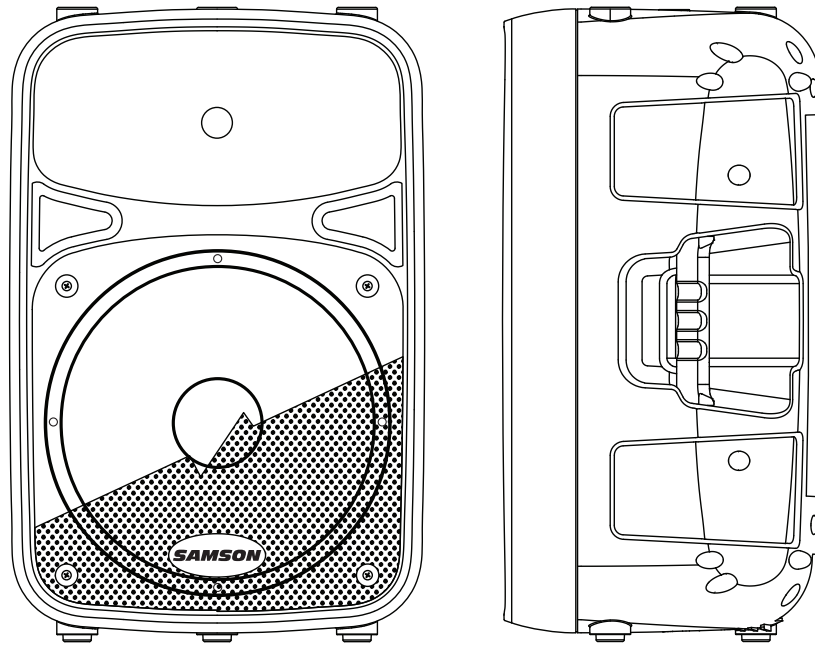

Here is a look at some the features of the Auro powered loudspeakers:

- 400 watt, two-way active loudspeakers for live sound applications
- 320W LF + 80W HF power amplifiers (peak)
- Ultra-wide, flat frequency response
- Custom-designed, heavy-duty, 12"/15" long throw low frequency drivers provide enhanced bass response
- 1.34" titanium diaphragm compression driver with 1" throat for smooth high-end reproduction
- Balanced Mic/Line input with Volume control and Peak LED
- Two-band LF and HF shelving equalizer
- XLR Line Output connectors to "daisy-chain" multiple Auro cabinets
- Multi-band dynamics processing with audibly transparent limiting
- Internal 24 dB/octave time aligned electronic crossover
- 30- and 45- degree monitor angles for near and far field coverage
- Standard 1 3/8-inch (35mm) speaker stand receptacle
- Versatile, portable design with integrated side handles
- Tuned, ported bass reflex design for extended low end
- Rugged, lightweight polypropylene cabinet construction

The following steps will help you set up your Auro D412/D415 loudspeakers.

## Setup

1. Turn the Level control on the rear panel fully counterclockwise.
2. Set the Bass and Treble EQ controls to the 12 o'clock position.
3. Turn the Power switch OFF.

## Connections

1. Connect either a line-level signal from your mixer (or other source) or a microphone to the Input jack on the Auro D412/D415 rear panel.
2. Connect the supplied power cable to the IEC socket on the back of the loudspeaker. Plug the power cable into an AC outlet.
3. Note: Always make sure that the AC outlet is configured with the correct voltage as indicated on the rear panel of the Auro loudspeaker.

## Operation

1. Switch the Auro's Power switch to the ON position.
2. Run an audio signal from your mixer, or talk into the microphone.
3. Slowly raise the Auro's Level control until you have reached the desired level.
4. If the volume from the speakers gets really loud, or you see the Peak indicator blinking frequently, turn down the Level control on the Auro D412/D415 a little until the Peak indicator does not light, or only lights occasionally with signal peaks.

# Rear Panel Layout

## 1. XLR Input Connector

This female XLR connector accepts either a balanced microphone or line level signal.

## 2. 1/4" Input Connector

Use this 1/4" input for connecting balanced microphone or balanced and unbalanced line level inputs.

## 3. Line Output

Male XLR connector used to link multiple Auro cabinets.

## 4. Level Control

This control adjusts the overall signal level at the input of the power amplifiers. For attenuating a line level signal, turn the control from fully counter-clockwise until 12 o'clock. For a mic level signal turn the Level control past 12 o'clock.

## 5. Bass EQ Control

This controls the low band of the loudspeaker equalizer, +/- 15 dB at 80 Hz.

## 6. Treble EQ Control

This controls the high band of the loudspeaker equalizer, +/- 15 dB at 12 kHz.

## 7. Peak Indicator

This RED LED lights when the amp is near the clipping point. If the Peak indicator lights frequently, turn down the Level control on the Auro loudspeaker or turn down the signal at the source, until the indicator does not light anymore, or lights occasionally with signal peaks.

## 8. Power Indicator

This LED lights GREEN when amp is active.

## 9. Power Switch

Switches on the Auro's main power.

## 10. Fuse Cover

The fuse is located behind the fuse cover. Always replace fuses with the same type of fuse.

## 11. AC Power Inlet

Connect the supplied standard IEC AC power cable here.

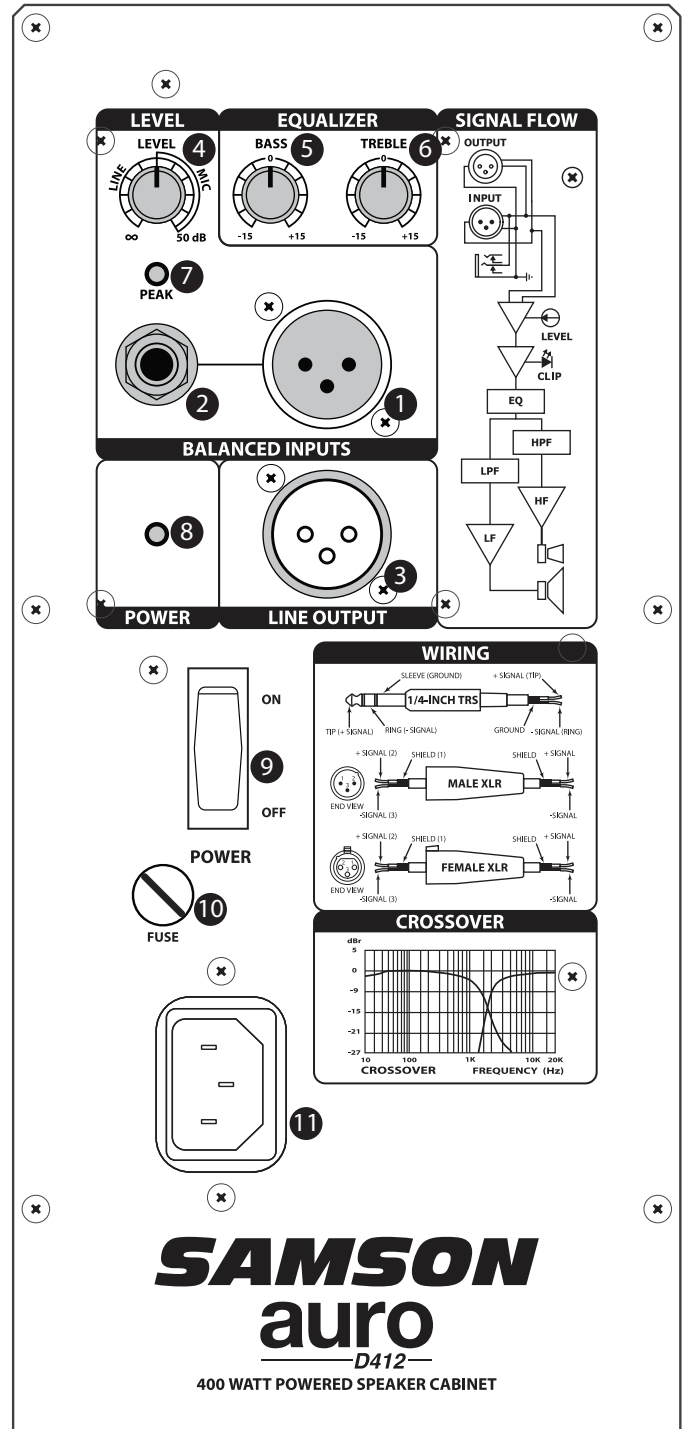

# Connecting a Microphone

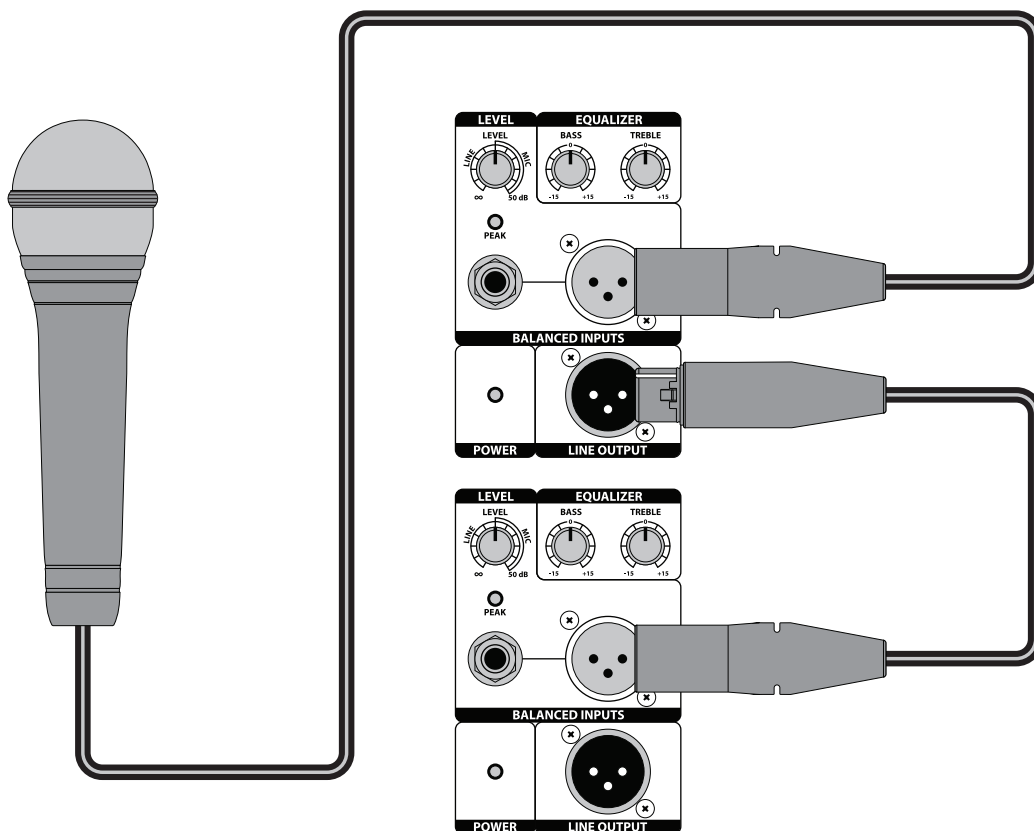

## Using a Microphone

- Be sure that the Auro D412/D415 Power switch is set to the off position.
- Turn the LEVEL control fully counterclockwise to the off position.
- Connect the power cable to an AC socket.
- Using a standard XLR cable, plug a microphone into the Auro's XLR INPUT.
- Switch the Power switch to the ON position.
- While speaking or singing into the microphone, slowly raise the LEVEL control until you have reached the desired level.
- For larger sound reinforcement you can run several monitors using the Line Output to daisy-chain one Auro to another.

# Connecting a Stereo Signal Source

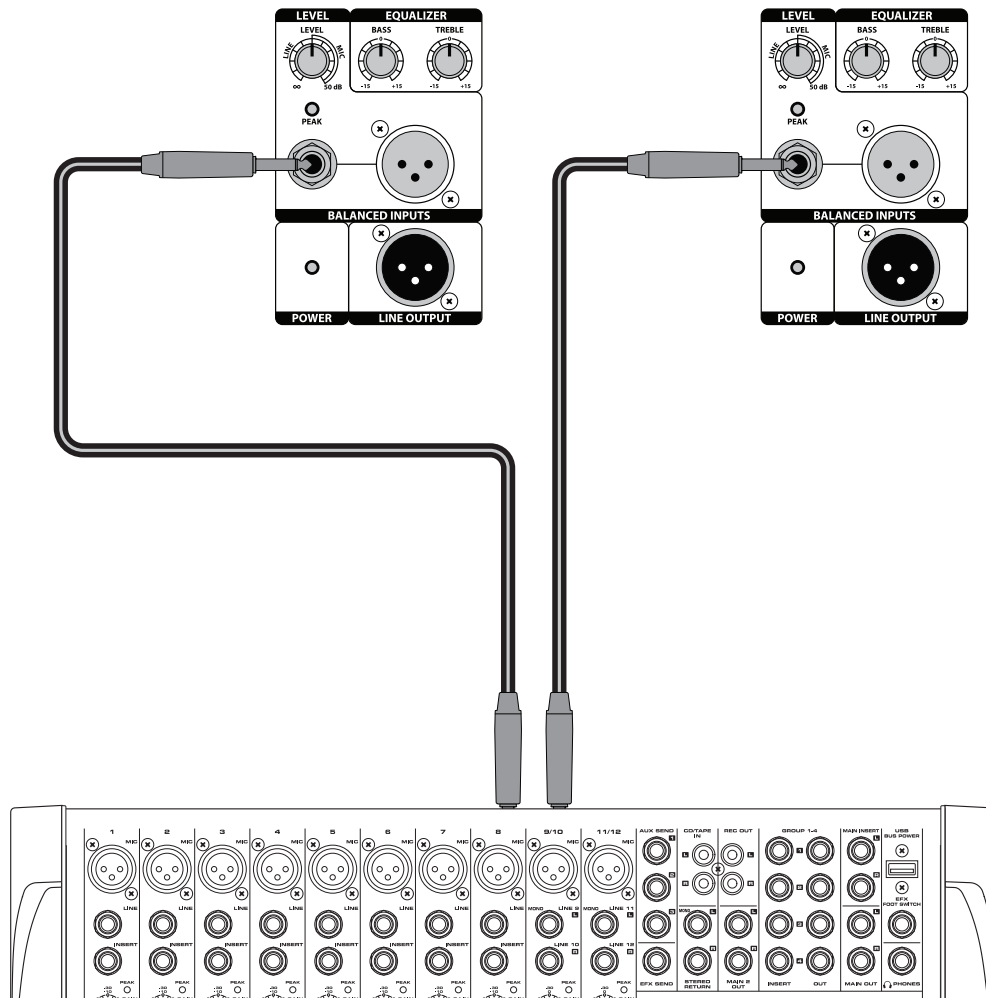

## Using a Stereo Line Level Signal

- Be sure that the Auro D412/D415 Power switch is set to the off position.
- Turn the LEVEL control fully counterclockwise to the off position.
- Connect the power cable to an AC socket.
- Using standard XLR or 1/4" cables, connect the line level signals from a mixer or keyboard into the Auro Inputs.
- Switch the Power switch to the ON position.
- Now, run an audio signal from your mixer (like music from a CD) while slowly raising the Auro's Level control until you have reached the desired level.

# Linking Two Speakers Per Side

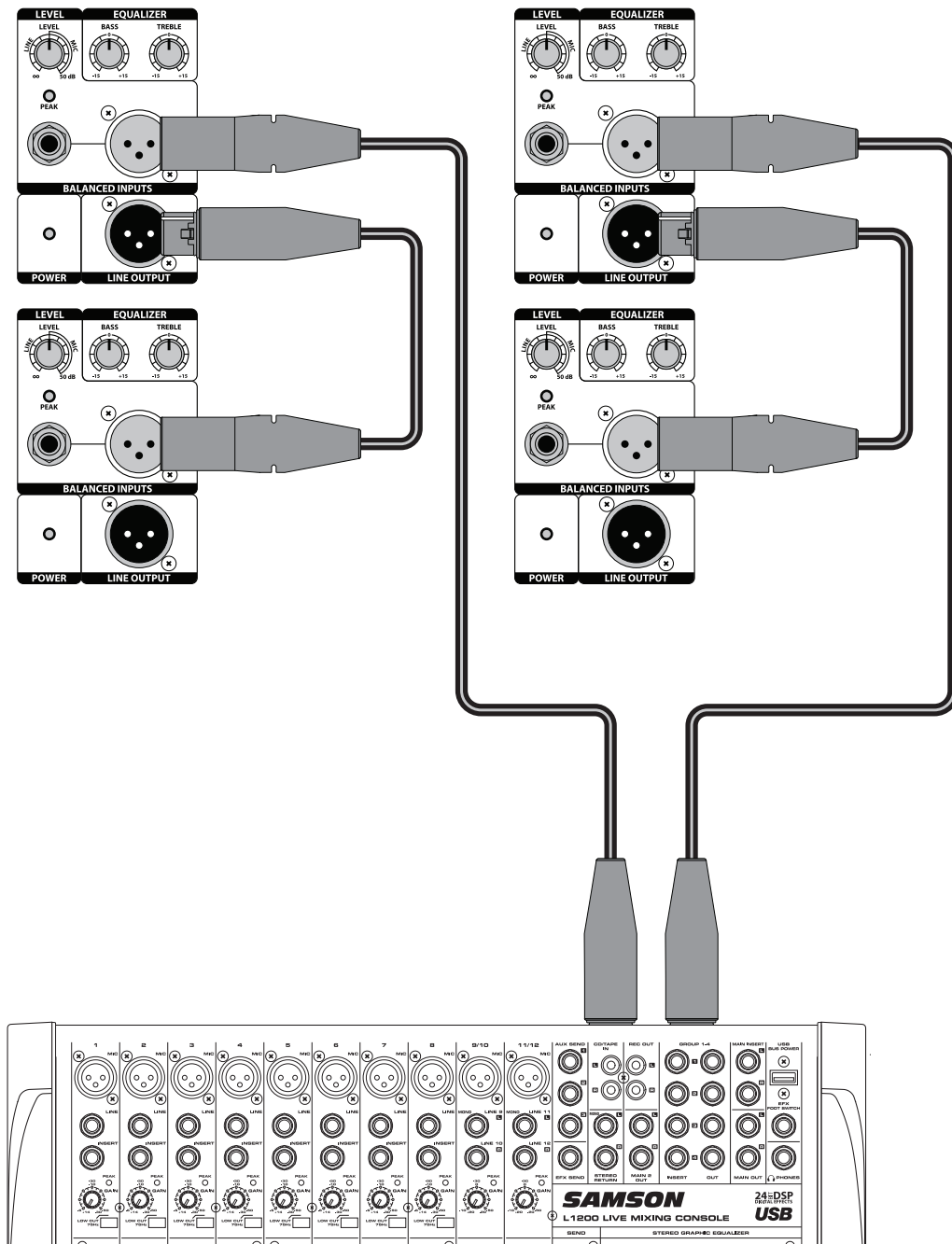

Linking two Auro cabinets per side:

- Turn the LEVEL control fully counterclockwise to the off position.
- Connect the left and right line-level outputs from a mixer to the inputs of two Auro loudspeakers.
- Feed the Line Outputs to another pair of Auro loudspeaker inputs.
- Now, run an audio signal from your mixer (like music from a CD) while slowly raising the Auro's Level control until you have reached the desired level.



---

# Positioning the Auro D412/D415

## Speaker Placement

Whenever possible, it is a good idea to raise the speakers above the heads of the listening audience. The Auro enclosures feature standard 1 3/8" pole mount receptacles with locking bolts, which are compatible with speaker stands from a variety of manufacturers. In a smaller setting like a school cafeteria, library, or a mall kiosk, you can also use the Auro loudspeaker in one of the tilt back monitor positions, which will improve the projection of the speakers and may eliminate the need for speaker stands.

Note: When using a speaker pole mount, be sure the pole is capable of supporting the weight of the Auro loudspeaker.

Note: Always have another person to assist when mounting the Auro speaker onto a speaker stand, or when adjusting the stand while the speaker is mounted on the stand.



## Using the Auro D412/D415 as a Floor Monitor

The Auro D412/D415 is an ideal solution for stage monitoring and thanks to its unique design, two wedge monitor positions are possible. When placed on its side, with the high frequency horn facing to the left of the enclosure, the Auro is tilted at a 30 degree angle, optimizing performance when used on a large stage. When placed on its side with the high frequency horn facing to the right of the enclosure, the Auro is tilted at a 45 degree angle optimizing performance when used on smaller stages.

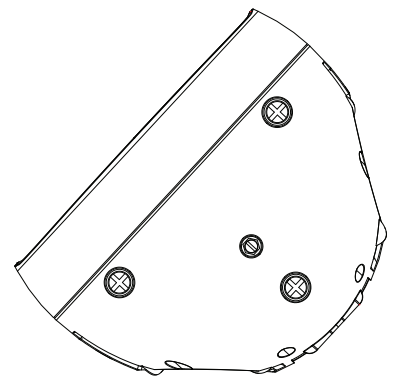

The Auro D412/D415 features balanced inputs and outputs, so connecting balanced and unbalanced signals is acceptable. Whenever possible, use balanced connections to other equipment to suppress interference.

## Unbalanced 1/4" Connector

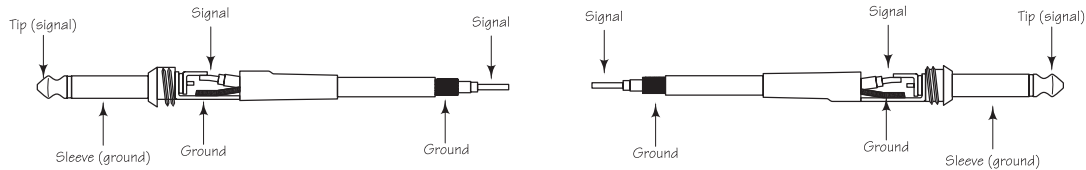

## Balanced TRS 1/4" Connector

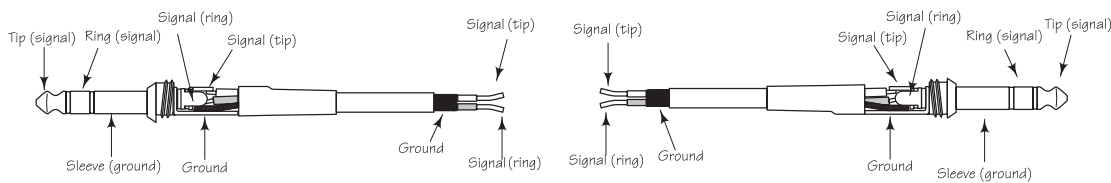

## XLR to XLR Balanced

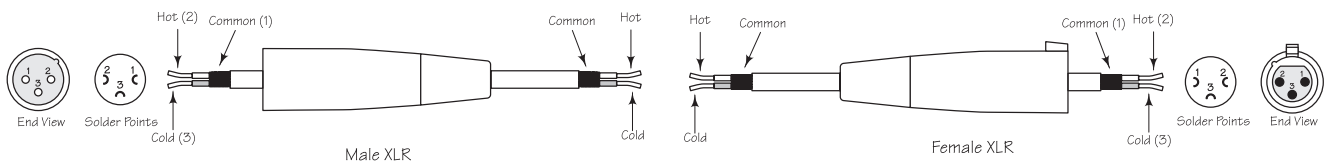

## Unbalanced 1/4" Connector to RCA

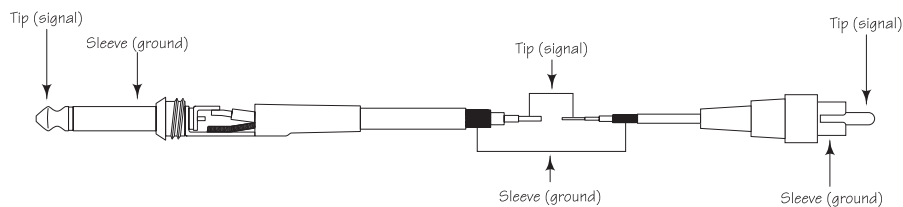

## XLR to Balanced 1/4-Inch

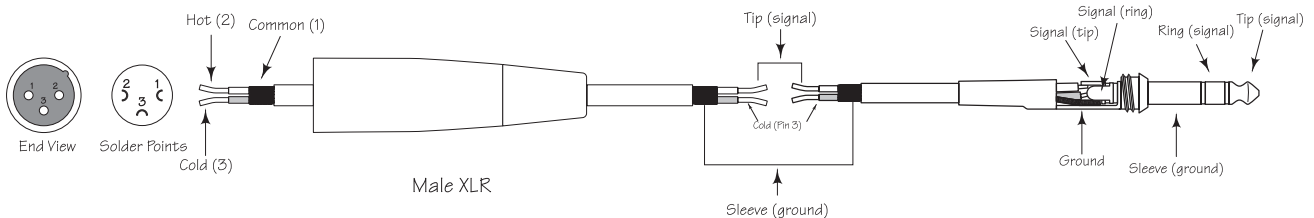

# Specifications

		D412	D415
<b>Output Power</b>			
Low Frequency	RMS Power	200 W @ 8 ohms	
	Peak Power	320 W @ 8 ohms	
	THD	< 1 %	
High Frequency	RMS Power	50 W @ 8 ohms	
	Peak Power	80 W @ 8 ohms	
	THD	< 1 %	
<b>Transducers</b>			
Low Frequency	12" bass transducer, 2.5" voice coil		15" bass transducer, 3" voice coil
High Frequency	1.34" (34 mm) titanium compression driver, edge-wound copper voice coil		
<b>Acoustic Performance</b>			
Frequency Response (-3 dB)	58 Hz to 20 kHz		55 Hz to 20 kHz
Maximum Sound Pressure Level	125 dB SPL @ 1		124 dB SPL @ 1 m
Limiter	Optical		
Horizontal Coverage Angle	90°		
Vertical Coverage Angle	60°		
<b>Electronic Crossover</b>			
Crossover Type	24 dB/oct Linkwitz-Riley		
Crossover Frequency	2.1 kHz		
<b>Input/Output</b>			
Inputs	Balanced XLR & 1/4" Mic/Line Connectors		
Output	Balanced XLR Line Output		
<b>Equalization</b>			
High	±15 dB @ 12 kHz, shelving		
Low	±15 dB @ 80 Hz, shelving		
<b>Power Supply</b>			
Power Consumption	456 W max.		
AC Connector	3-pin IEC 250 VAC, 20 A male		
Fuse	100 - 115 VAC T5AL / 250 V		
	220 - 240 VAC T2.5AL / 250 V		
<b>Dimensions and Weight</b>			
Dimensions	in	14" L x 10.8" W x 21.5" H	17.75" L x 13.5" W x 27.5" H
	mm	356 mm L x 275 mm W x 546 mm H	450 mm L x 342 mm W x 698 mm H
Weight	lbs	35.8	49
	kg	16.25	22.25
<b>Mounting</b>			
Mounting Method	Integral 1 3/8" Pole Mount Receptacle		
Fly Point	1		

Specifications are subject to change without notice.

# D412

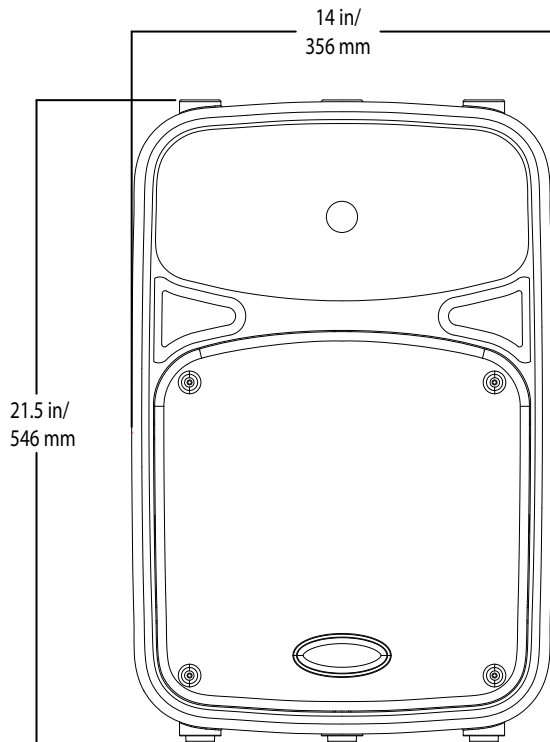
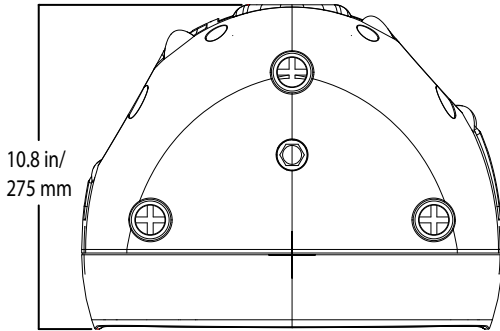

# D415

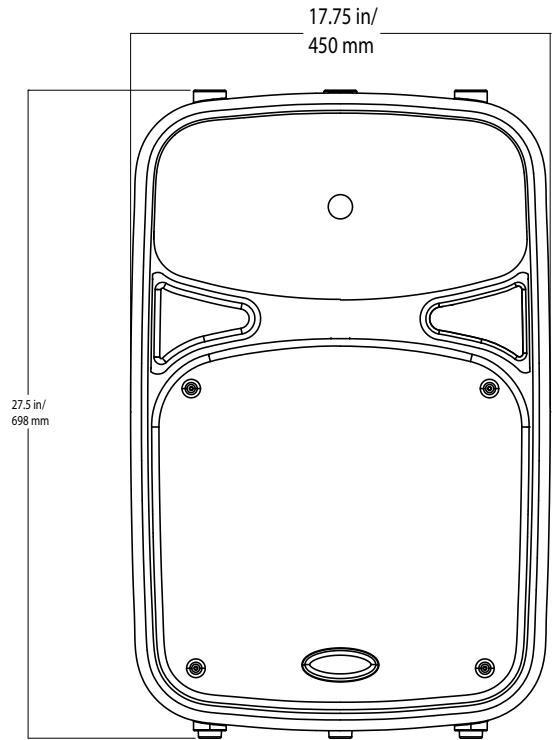
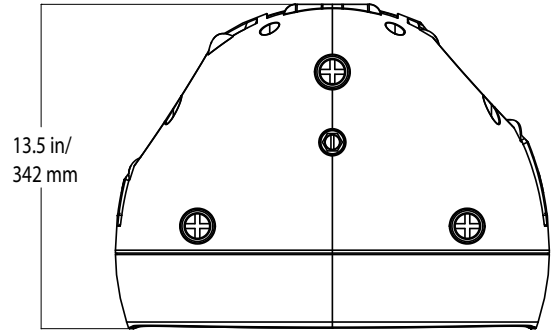

ENGLISH

FRANÇAIS

DEUTSCHE

ESPAÑOL

ITALIANO